



Starling Madison Lofquist, Inc.
Consulting Structural and Forensic Engineers

5224 South 39th Street, Phoenix, Arizona 85040
tel: (602) 438-2500 fax: (602) 438-2505 ROC#291316 www.smleng.com

Pegasus Solar™ Inc.
100 West Ohio Avenue
Richmond, CA 94804

February 1, 2017

page 1 of 3

Attn: Mr. Kai Stephan, CEO

Subject: Pegasus Solar™ LightSpeed Concrete Tile Roof Solar Mounting System with Rail Allowable Loads

SML Job No.: 182-15

Dear Mr. Stephan:

We have analyzed the Pegasus Solar™ LightSpeed photovoltaic (PV) panel roof mount system for its use on concrete tile roof with a rail attachment and determined that, for the configurations and criteria described below, it is in compliance with the applicable sections of the following reference documents:

- Codes: ASCE/SEI 7-05 & 7-10 Min. Design Loads for Buildings & Other Structures
International Building Code 2009, 2012 & 2015 Edition
International Residential Building Code 2009, 2012 & 2015 Edition
- Other: Aluminum Design Manual, ADM-2010 & 2015 Edition

This letter is to address the use and allowable loads for the Pegasus Solar™ LightSpeed Concrete Tile Roof Solar Mounting System as shown in diagram TR1 below. We have reviewed the test data for the Concrete Tile Roof Solar Mounting System prepared by Western Technologies (WT), tested January 7, 2017 as well as typical loading and anchorage conditions for common rail type solar racking systems. We have determined that, subject to the limitations outlined below, the Pegasus Solar™ LightSpeed Concrete Tile Roof Solar Mounting System is suitable for most L-Foot type rooftop solar racking systems.

The Pegasus Solar™ LightSpeed concrete tile roof photovoltaic (PV) panel roof mount system for installations with a rail by others is comprised of a 6000 series aluminum standoff post and T-bolt, steel sled, cold-formed steel flashing, and 5/16-18 stainless steel bolts and nuts to fasten the mounting system together. The system is attached to the roof wood rafters or truss top chords with (2) 5/16" diameter x 3.5" long 18-8 stainless steel wood lag screws.

We tested the mounting system with the (2) 5/16" diameter 18-8 stainless steel wood lag screws passing through metal flashing, 15/32" thick plywood and finally penetrating 2.0" (see note 1) into 2x White Fir, with a specific gravity (G) of 0.43, in the center third of the 1.5" wide face to model either a 1.5" wide roof truss top chord or roof rafter. The WT report indicates the failure mode is the pullout of the lag screw from the wood framing.

The results of the WT report give the allowable load for pullout (uplift), compression and lateral shear for anchorage in White Fir timber with a specific gravity (G) of 0.43 as follows:

Allowable Uplift = 633 lbs, Allowable Compression = 771 lbs, Allowable Shear = 496 lbs

As an alternate to the tested values, the following values may be used when installing into a wood substrate with a specific gravity (G) of 0.50. The increase in capacity was determined using the ANSI/AF&PA NDS-2012 National Design Specification (NDS) for Wood Construction adjustment factor of $1 / 1-(0.50-G)$ where G is the tested specific gravity.

Allowable Uplift = 681 lbs, Allowable Compression = 829 lbs, Allowable Shear = 533 lbs

The values provided above were developed by taking the average of four tests divided by a factor of safety of 3.0 for wood connection failure. These values do not include any additional increases or load factors, and it is up to the end user to determine any increases permissible by the code. The test loads were applied at the surface of the standoff post aligned with the lag screw. Any adverse effects due to additional height or eccentricity of connected components shall be considered by the end user of this letter.

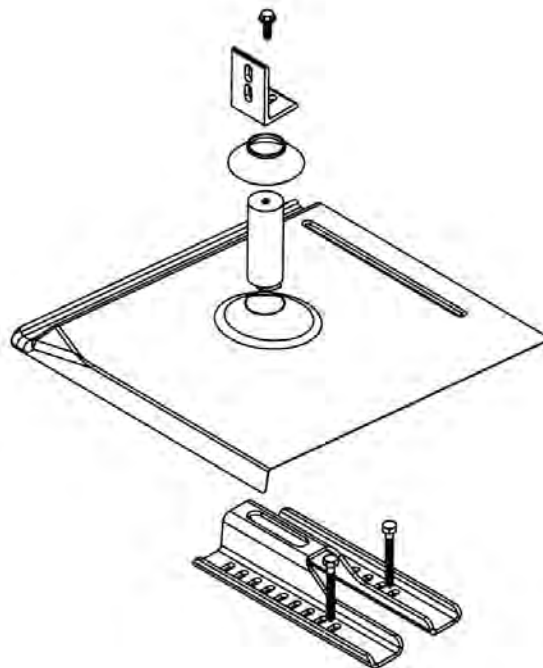

Diagram TR1. Tile Rail Option (L-Foot by Others)

Notes – Tested values are based on the following criteria:

1. 2.0” minimum penetration of lag screw into 2x roof framing, excluding the tapered tip portion.
2. PV panel must comply with mechanical load requirements of UL 1703 OR 2703.

Our analysis assumes that the connections and associated hardware are installed in a workmanlike manner in accordance with the LightSpeed Mount Installation Manual and generally accepted standards of construction practice. It is the responsibility of the contractor to verify that the strength of the roof framing meets the minimum properties used in the tests and can safely support the maximum imposed loads stated within this document. Starling Madison Lofquist, Inc. and Pegasus Solar™ assume no liability beyond what is specifically shown in this letter. Additional information is available at the Pegasus Solar™ web site, <http://pegasussolar.com/>

Please feel free to contact me at your convenience if you have any questions.

Respectfully yours,



Tres J. Warner, P.E.
Design Division Manager

Jesse Light, P.E.
Sr. Structural Engineer