

Rafter or Deck Attach!

- No pilot holes
- Pre-installed sealant
- No caulking, no ripping shingles



Pre-installed sealant

Before: Sealant contained by protective cage. No contact with hands or tools.



Instant, watertight seal

After: Non-hardening sealant automatically fills all gaps, overlays and butt joints.



Install in any season

Install in 0 to 170° F weather, including rain and sleet. Watertight for life.

The Ultimate Comp Roof Attachment

Simple to use. Works for rafter or deck attach. No caulking, no ripped shingles, no mess. Pre-installed sealant acts as a chemical flashing and fills all gaps, voids, and butt joints for an instant, watertight seal.



25-Year Warranty

Manufactured with advanced materials and coatings to outlast the roof itself



Code Compliant

Fully IBC/CBC code compliant
Exceeds ASCE 7-22 standards
UL2703 certified



Self-Healing

Proprietary non-hardening sealant will flex and reseal over years of thermal expansion and contraction



Larger Spans

Extra-large L-foot and proprietary screws result in larger spans between mounts

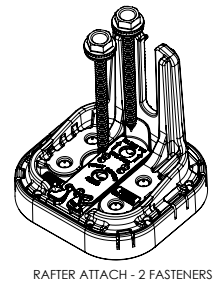
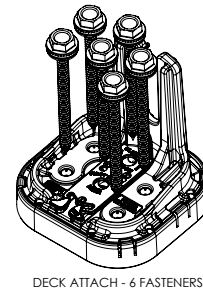
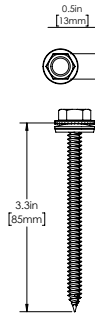
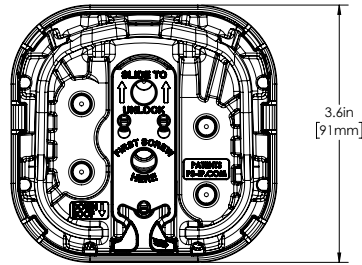
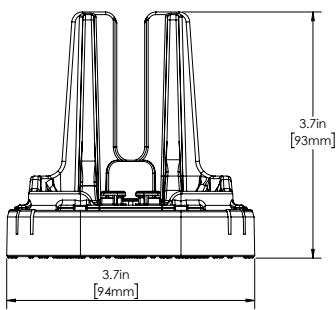
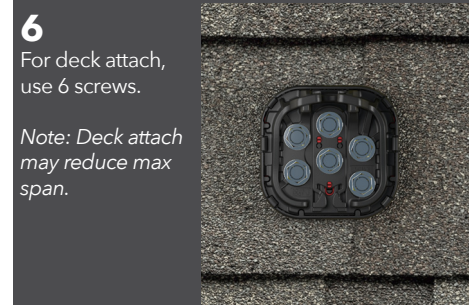

SPECIFICATIONS	INSTAFLASH KITS			
	PIF2-B0	PIF2-BDT	PIF2-M0	PIF2-MDT
Finish	Black		Mill	
Kit Contents	Black InstaFlash2	Black InstaFlash2, Dovetail T-bolt	Mill InstaFlash2	Mill InstaFlash2, Dovetail T-bolt
Attachment Type	Rafter & Deck Attach			
Roof Fasteners	1/2" Socket Driven; PF-DRW85 (sold separately in boxes of 24)			
Roof Type	Sloped Roof: Composition Shingle, Rolled Asphalt Flat Roof: Modified Bitumen Roof, Built-Up Roof			
Flashing Type	Factory Installed Non-Drying, Non-Skinning Butyl Based Chemical Flashing			
Installation Temperature	0° F to 170° F			
Cure Time	Instantly Waterproof; Non-Hardening			
Service Temperature	-40° F to 195° F			
Certifications	IBC, ASCE/SEI 7-16 & 7-22, UL2703			
Install Application	Most Railed Systems			
Kit Quantity	24			
Boxes Per Pallet	36			



SCAN FOR
INSTALLATION
VIDEO



SCAN FOR
FREE TRIAL

See www.ps-ip.com for intellectual property details. All rights reserved. ©2024 Pegasus Solar Inc.